

RoHS Compliant

REV	ECN No.	DATE	REMARK
E	ECN1908006	2019.08.22	增加6.69协会尺寸公差
F	ECN1912017	2019.12.16	外壳增加D/C规格
G	ECN2009002	2020.09.08	增加PA9T料规格

NOTE:

- Electrical Characteristics:
  - 1-1: Current Rating: 5A
  - 1-2: VOLTAGE RATING:5.0V
  - 1-3: Insulation Resistance: 100MΩ Min.
  - 1-4: Contact Resistance:
    - VBUS & GND PINS AND OTHER PINS: 40mΩ/PIN MAX.
    - SHIELD:50mΩ/MAX.
    - SHIELD:LLCR MAX. CHANGE OF ALL PINS: 10mΩ.
  - 1-5: Dielectric Withstanding Voltage: 100V/AC 1Minute
- Mechanical Characteristics:
  - Insertion Force: 5~20N
  - Extraction Force: Initial: 8~20N
  - After durability: 6~20N
  - Durability :10000 Cycles
- Operating Temperature: -25°C TO +85°C

4.PART NUMBER CODE:(产品料号)

Z-CF044 S X X XX R - A - 01  
(1) (2) (3)

- (1) HOUSING MATERIAL: C:PA9T
- (2) HOUSING COLOR: B:BLACK
- (3) CONTACTS PLATED: 12:接触镀金3u"其它GF
- (4) PACKING OPTIONS R:TAPE & REEL

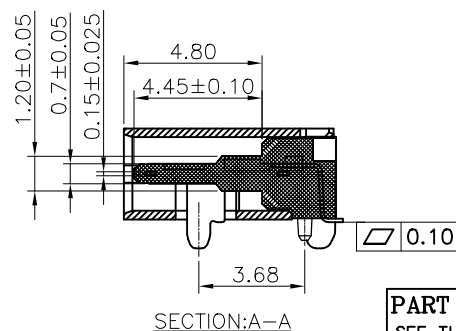
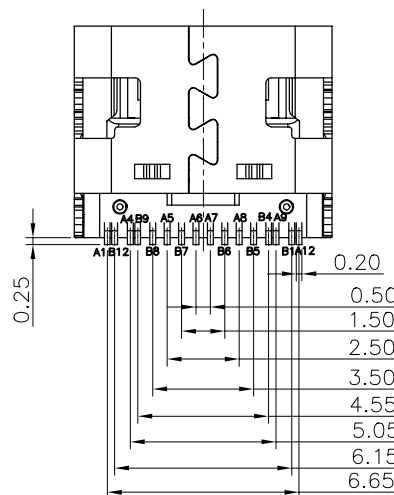
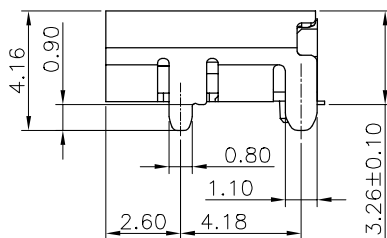
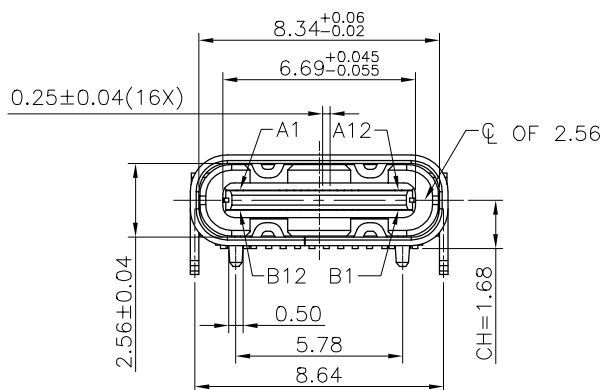
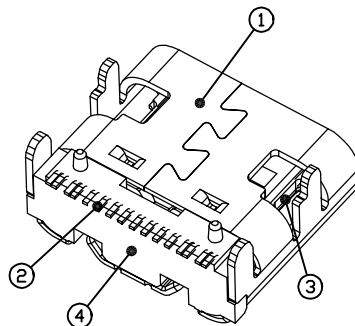
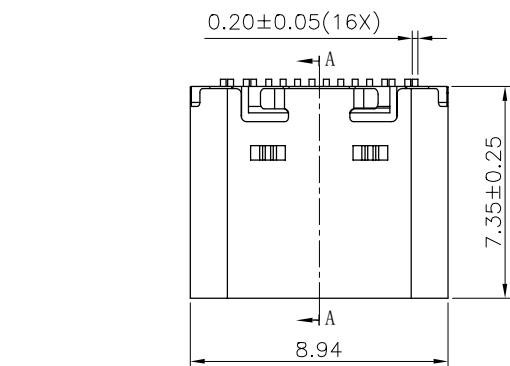

TABLE:

NO	PART	Q'TY	Material
1	SHELL	1	SUS 304,Ni PLATED 30u"Min
2	CONTACT	16	COPPER STEEL,Ni 50u"Min;Au u"
3	MID PLATE	1	SUS 301,NO PLATING
4	HOUSING	1	HIGH TEMPERATURE RESISTANT PLASTIC PA9T BLACK UL94 V-0

<b>PART NO.:</b> SEE THE PART NUMBER CODE		GOLDCONN TECHNOLOGIES COMPANY LIMITED		DRAWN BY SAM	DATE 2020.09.08	
QUALITY SYMBOL 0	GENERAL TOLERANCES (UNLESS SPECIFIED)		TITLE USB CF 16PIN (L=7.35)WITH POST			
	x.xxxx	± ---	DWG.NO. CF044-01	SHEET NO. 1 OF 3	CHECKED BY JAY	DATE 2020.09.08
	x.xxx	± 0.10			APPROVED BY JACKY	DATE 2020.09.08
	x.xx	± 0.25	SCALE 1:1			
	x.x	± 0.30	DIMENSION STYLE MM ONLY		DESIGN UNITS METRIC	
ANGULAR	± ---°	THIRD ANGLE PROJECTION		frame size: A4		

RoHS Compliant 

REV	ECN No.	DATE	REMARK
E	ECN1908006	2019.08.22	增加6.69协会尺寸公差
F	ECN1912017	2019.12.16	外壳增加D/C规格
G	ECN2009002	2020.09.08	增加PA9T料规格

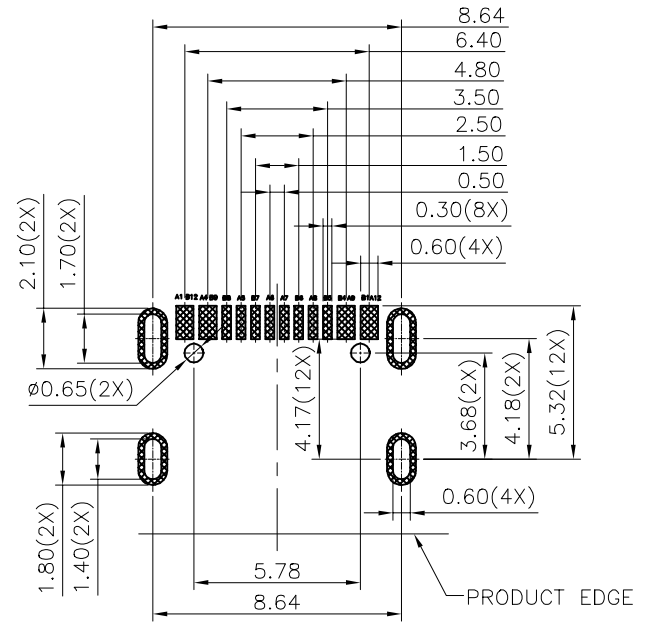
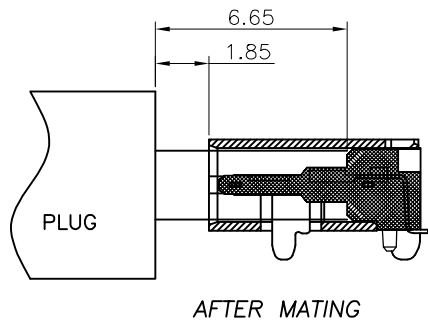

RECOMMENDED PCB LAYOUT(TOP VIEW)  
THICKNESS 0.80MM;DEFAULT TOLERANCE:±0.05

USB TYPE-C PIN ASSIGNMENTS

PIN NUMBER	SIGNAL NAME	PIN NUMBER	SIGNAL NAME
A1	GND	B12	GND
A4	VBUS	B9	VBUS
A5	CC1	B8	SBU2
A6	Dp1	B7	Dn2
A7	Dn1	B6	Dp2
A8	SBU1	B5	CC2
A9	VBUS	B4	VBUS
A12	GND	B1	GND

PART NO.: SEE THE PART NUMBER CODE		GOLDCONN TECHNOLOGIES COMPANY LIMITED		DRAWN BY SAM	DATE 2020.09.08
GENERAL TOLERANCES (UNLESS SPECIFIED)		TITLE USB CF 16PIN (L=7.35)WITH POST		CHECKED BY JAY	DATE 2020.09.08
QUALITY SYMBOL	0	x.xxxxx	±	---	
	0	x.xxx	±	0.10	
	0	x.xx	±	0.25	
	0	x.x	±	0.30	
	0	ANGULAR	±	---	
DWG.NO. CF044-01		SHEET NO. 2 OF 3		APPROVED BY JACKY	DATE 2020.09.08
DIMENSION STYLE MM ONLY		DESIGN UNITS METRIC		SCALE 1:1	
THIRD ANGLE PROJECTION					

RoHS Compliant 

REV	ECN No.	DATE	REMARK
E	ECN1908006	2019.08.22	增加6.69协会尺寸公差
F	ECN1912017	2019.12.16	外壳增加D/C规格
G	ECN2009002	2020.09.08	增加PA9T料规格

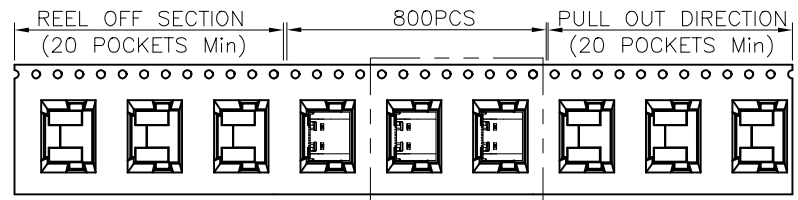

SEE DETAIL X

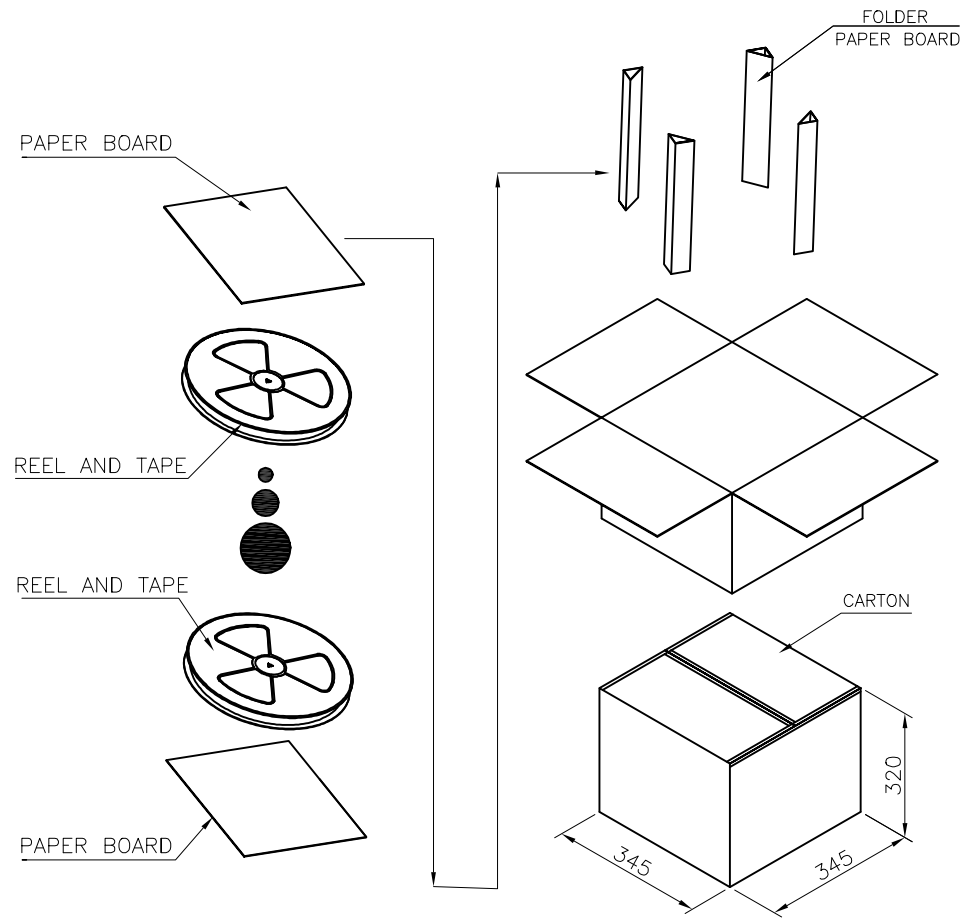
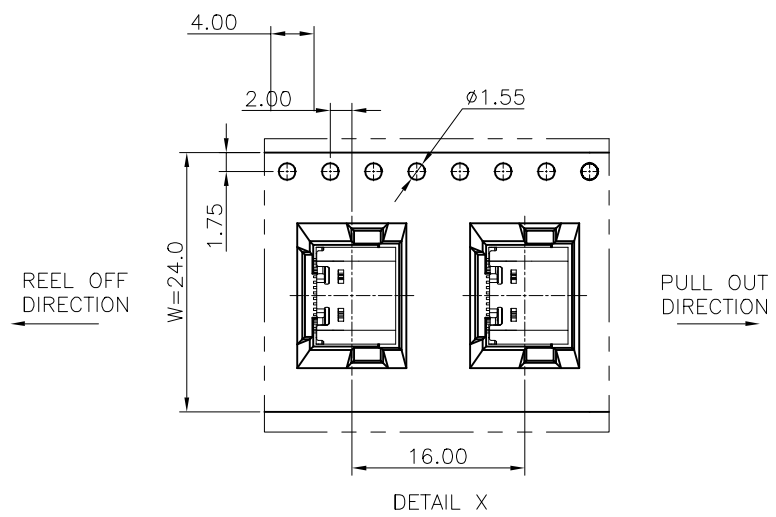
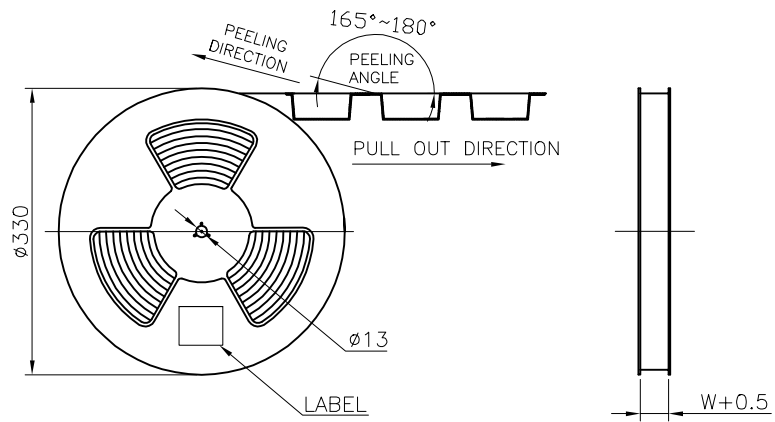

	REEL	CARTON
CONNECTOR (PCS)	800	8000

PART NO.: SEE THE PART NUMBER CODE		GOLDCONN TECHNOLOGIES COMPANY LIMITED		DRAWN BY SAM	DATE 2020.09.08	
QUALITY SYMBOL 0 0 0 0 0	GENERAL TOLERANCES (UNLESS SPECIFIED)		TITLE USB CF 16PIN (L=7.35)WITH POST			
	x.xxxx	± ---	DWG.NO. CF044-01	SHEET NO. 3 OF 3	CHECKED BY JAY	DATE 2020.09.08
	x.xxx	± 0.10			APPROVED BY JACKY	DATE 2020.09.08
	x.xx	± 0.25	DIMENSION STYLE MM ONLY		DESIGN UNITS METRIC	SCALE 1:1
	x.x	± 0.30	THIRD ANGLE PROJECTION			
ANGULAR	± ---	frame size: A4				