

RoHS Compliant

REV	ECN No.	DATE	REMARK
A	NEW	2022.02.14	NEW RELEASE

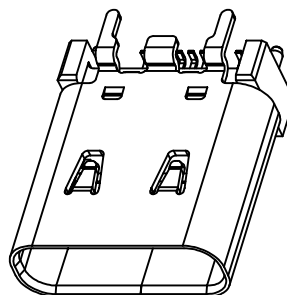

NOTE:  
 1.MATERIAL SPECIFICATION:  
 1-1.HOUSING:HIGH TEMPERATURE RESISTANT PLASTIC,UL94 V-0.  
 1-2.TERMINAL: COPPER ALLOY  
 1-3.MID PLATE: STAINLESS STEEL(SUS301 T=0.15mm)  
 1-4.FRONT SHELL: STAINLESS STEEL(SUS304 T=0.3mm)  
 2.PLATING SPECIFICATION:  
 2-1.TERMINAL:  
 Ni 50u" MIN. UNDER PLATED OVER ALL.  
 Au PLATED ON THE FUNCTIONAL AREA OF CONTACT.  
 (GOLD PLATING THICKNESS FOLLOW THE P/N)  
 PLATING SPECIFICATIONS OF THE SOLDER AREA FOLLOW THE P/N  
 2-2.FRONT SHELL:  
 Ni 30u" MIN. UNDER PLATED OVER ALL.  
 2-3.MID PLATE  
 CLEAR ONLY  
 2-4.EMI PLATE:  
 CLEAR ONLY  
 3.MECHANICAL PERFORMANCE,  
 3-1.INSERTION FORCE: 0.5~2.0kgf.  
 3-2.REMOVAL FORCE: 0.8kgf~2.0kgf.  
 3-3.DURABILITY: 10000 CYCLES.  
 4.ELECTRICAL PERFORMANCE,  
 4-1. VOLTAGE RATING:5 V DC/AC (RMS. max)  
 CURRENT RATING:5 AMPS. FOR TOTAL VBUS/GND PINS;  
 1.25AMPS FOR CC PIN,0.25 AMPS. FOR ALL OTHER CONTACT.  
 4-2. LLCR:.  
 VBUS & GND PINS AND OTHER PINS: 40mΩ/PIN MAX.  
 SHIELD: 50mΩ/MAX.  
 LLCR MAX. CHANGE OF ALL PINS: 10mΩ.  
 4-3.INSULATION RESISTANCE: 100MΩ MIN  
 4-4.DIELECTRIC WITHSTAND VOLTAGE,AC 100V FOR 1 MINUTE.  
 5. ENVIRONMENTAL PERFORMANCE:  
 OPERATING TEMPERATURE: -25°C~+85°C.  
 6.IR REFLOW:  
 THE PEAK TEMPERATURE ON THE BOARD SHALL  
 BE MAINTAINED FOR 10 SECONDS AT 260°C.

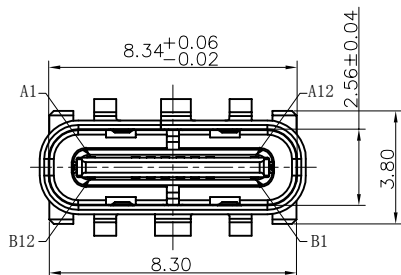
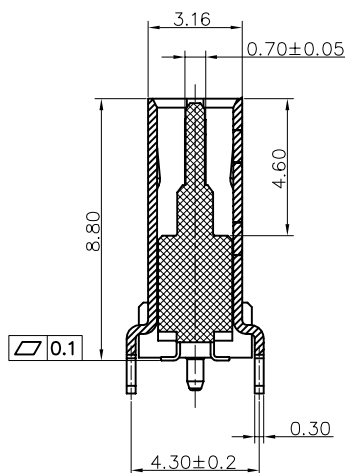
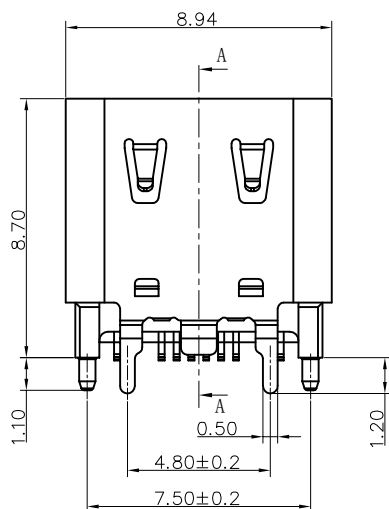

SECTION A-A  
SCALE 1:1

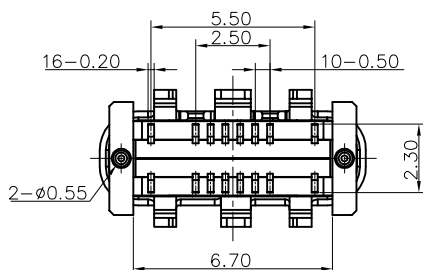
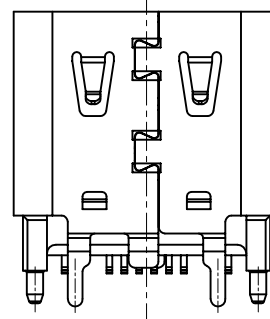

7.PART NUMBER CODE: (产品料号)  
 CF 1 16 - 011 S X X XX R - 02  
 (1)(2) (3) (4) (5) (6)

- (1) 产品形态: 1:180度直立式
- (2) Pin No.: 16:16PIN
- (3) HOUSING MATERIAL: L:LCP
- (4) HOUSING COLOR: B:BLACK
- (5) CONTACTS PLATED: 12:接触镀金Au\*其它GF
- (6) PACKING OPTIONS: R:TAPE & REEL

PART NO.: SEE THE PART NUMBER CODE		GOLDCONN TECHNOLOGIES COMPANY LIMITED		DRAWN BY SAM	DATE 2022.02.14
QUALITY SYMBOL 0	GENERAL TOLERANCES (UNLESS SPECIFIED)	TITLE TYPE C母座16P 直立式SMT H=8.8		CHECKED BY JAY	DATE 2022.02.14
	x.xxxx	±	---	APPROVED BY JACKY	DATE 2022.02.14
	x.xxx	±	0.10		
	x.xx	±	0.20		
x.x	±	0.30			
ANGULAR	±	---			
DWG.NO. CF116-010-02		SHEET NO. 1 OF 2		THIRD ANGLE PROJECTION	
DIMENSION STYLE MM ONLY		DESIGN UNITS METRIC		SCALE 1:1	

frame size: A4

WITH PICK UP COVER

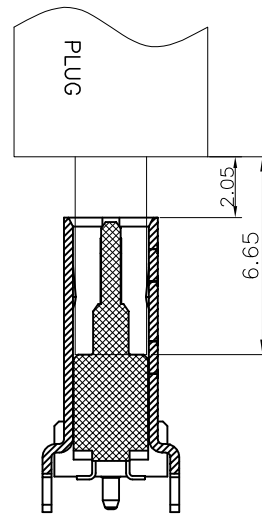
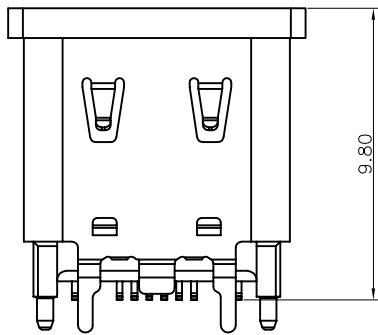
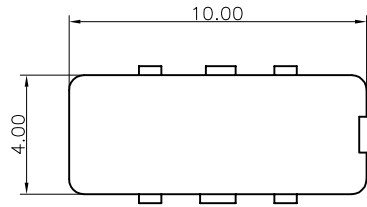

AFTER MATING

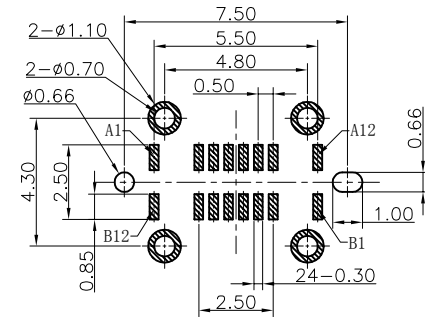

RECOMMEND P.C.B LAYOUT (COMPONENT SIDE)  
TOLERANCE FOR PCB LAYOUT IS ±0.05

USB TYPE C PIN ASSIGNMENTS

PIN NUMBER	SIGNAL NAME	PIN NUMBER	SIGNAL NAME
A1	GND	B12	GND
A4	VBUS	B9	VBUS
A5	CC1	B8	SBU2
A6	DP1	B7	DN2
A7	DN1	B6	DP2
A8	SBU1	B5	CC2
A9	VBUS	B4	VBUS
A12	GND	B1	GND

PART NO.: SEE THE PART NUMBER CODE		GOLDCONN TECHNOLOGIES COMPANY LIMITED		DRAWN BY SAM	DATE 2015.05.10	
QUALITY SYMBOL 0 $\nabla$ 0 = 0 $\nabla$ 0	GENERAL TOLERANCES (UNLESS SPECIFIED)		TITLE TYPE C母座16P直立式SMT H=8.8			
	x.xxxx	± ---	DWG.NO. CF116-010-02	SHEET NO. 2 OF 2	CHECKED BY JAY	DATE 2015.05.10
	x.xxx	± 0.10			APPROVED BY JACKY	DATE 2015.05.10
	x.xx	± 0.20	DIMENSION STYLE MM ONLY	DESIGN UNITS METRIC	SCALE 1:1	THIRD ANGLE PROJECTION
x.x	± 0.30					
ANGULAR	± ---°					