

F
E
D
C
B
A

F
E
D
C
B
A

WITH PICK UP COVER

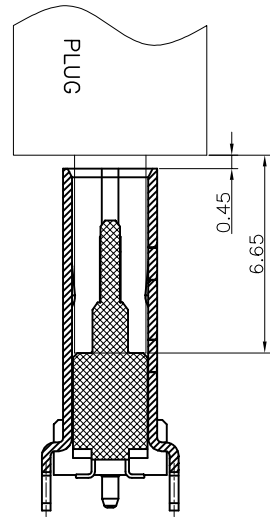
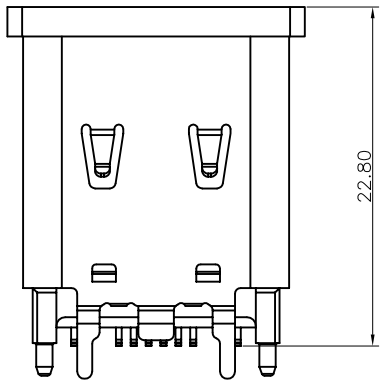
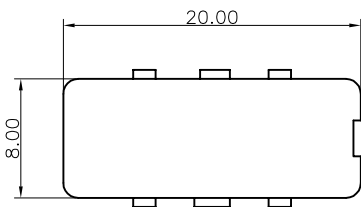

AFTER MATING

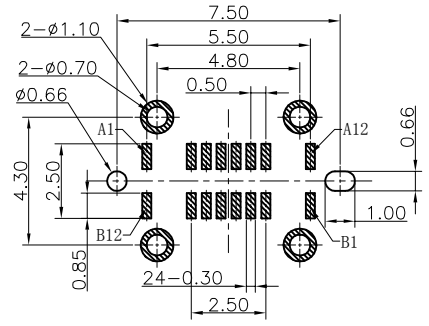

RECOMMEND P.C.B LAYOUT(COMPONENT SIDE)
TOLERANCE FOR PCB LAYOUT IS ±0.05

USB TYPE C PIN ASSIGNMENTS

PIN NUMBER	SIGNAL NAME	PIN NUMBER	SIGNAL NAME
A1	GND	B12	GND
A4	VBUS	B9	VBUS
A5	CC1	B8	SBU2
A6	DP1	B7	DN2
A7	DN1	B6	DP2
A8	SBU1	B5	CC2
A9	VBUS	B4	VBUS
A12	GND	B1	GND

PART NO.: SEE THE PART NUMBER CODE		GOLDCONN TECHNOLOGIES COMPANY LIMITED		DRAWN BY SAM	DATE 2015.05.10	
QUALITY SYMBOL 0 ∇ = 0	GENERAL TOLERANCES (UNLESS SPECIFIED)		TITLE TYPE C母座16P直立式SMT H=10.4			
	x.xxxx	± ---	DWG.NO. CF116-013-02	SHEET NO. 2 OF 2	CHECKED BY JAY	DATE 2015.05.10
	x.xxx	± 0.10			APPROVED BY JACKY	DATE 2015.05.10
	x.xx	± 0.20				
	x.x	± 0.30				
ANGULAR	± ---°	DIMENSION STYLE MM ONLY	DESIGN UNITS METRIC	SCALE 1:1	THIRD ANGLE PROJECTION	