

RoHS Compliant

REV	ECN No.	DATE	REMARK
A0	NEW	2019.05.22	NEW RELEASE

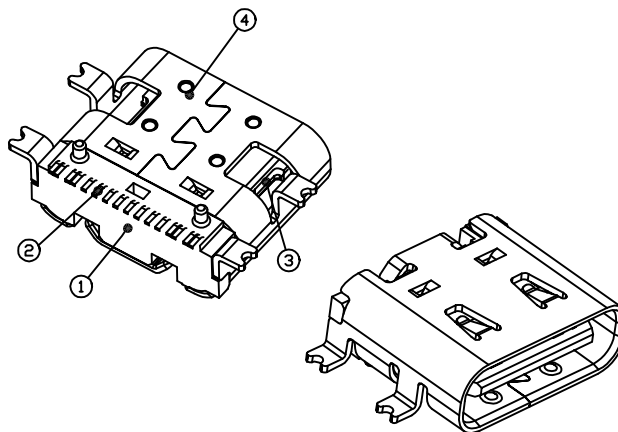
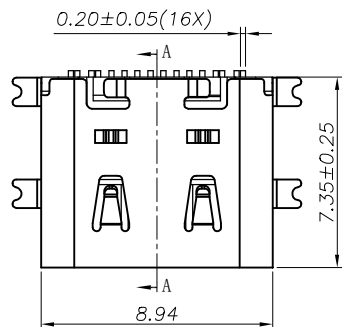

NOTE:

- Electrical Characteristics:
  - 1-1: Current Rating: 5A For Pin(A4,A9,B4,B9)  
1.25A For Pin(B5)  
0.25A For Others Pin
  - 1-2: VOLTAGE RATING:5.0V
  - 1-3: Insulation Resistance: 100MΩ Min.
  - 1-4: Contact Resistance:  
VBUS & GND PINS AND OTHER PINS: 40mΩ/PIN MAX.  
SHIELD:50mΩ/MAX.  
SHIELD:LLCR MAX. CHANGE OF ALL PINS: 10mΩ.
  - 1-5: Dielectric Withstanding Voltage: 100V/AC 1Minute
- Mechanical Characteristics:
  - Insertion Force: 5~20N
  - Extraction Force: Initial: 8~20N  
After durability: 6~20N
  - Durability :10000 Cycles
- Operating Temperature: -25°C TO +85°C

4. PART NUMBER CODE:(产品料号)  
C F179 - 16 S L B XX R - 02  
(1) (2) (3) (4)

- (1) HOUSING MATERIAL:  
L:LCP
- (2) HOUSING COLOR:  
B:BLACK
- (3) CONTACTS PLATED:  
12:接触镀金3u\*其它GF
- (4) PACKING OPTIONS  
R:TAPE & REEL

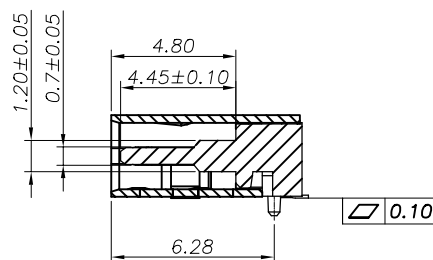
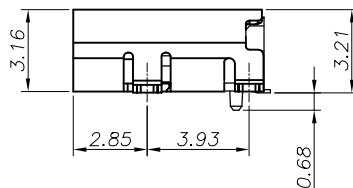
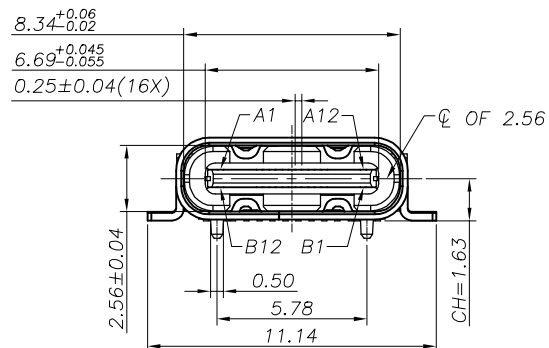

SECTION:A-A

TYPE:

NO.	DESCRIPTION	MATERIAL	REMARKS	QTY
4	SHELL	SUS304 1/2H T=0.30mm	NICKEL 30u" MIN PLATING	1PCS
3	SHIELDING PLATE	SUS301 3/4H T=0.15mm	---	1PCS
2	CONTACT	C18400-H T=0.12mm	NI 50u" MIN. UNDER PLATED OVER ALL Au 3u" PLATED ON THE FUNCTIONAL AREA OF CONTACT. PLATING G/F OF THE SOLDER AREA.	2SET
1	HOUSING	LCP UL94V-0	BLACK	1PCS

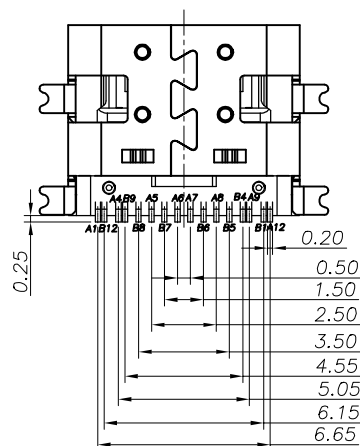

PART NO.: SEE THE PART NUMBER CODE		GOLDCONN TECHNOLOGIES COMPANY LIMITED		DRAWN BY SAM	DATE 2019.05.22
GENERAL TOLERANCES (UNLESS SPECIFIED)		TITLE USB CF 16PIN L=7.35 SMT TYPE		CHECKED BY JAY	DATE 2019.05.22
QUALITY SYMBOL	0	x.xxxxx	± ---	DWG.NO. CF179-16-02	SHEET NO. 1 OF 2
	0	x.xxx	± 0.10	SCALE 1:1	
	0	x.xx	± 0.20	APPROVED BY JACKY	
	0	x.x	± 0.30	DATE 2019.05.22	
	0	ANGULAR	± ---	THIRD ANGLE PROJECTION	

RoHS Compliant 

REV	ECN No.	DATE	REMARK
A0	NEW	2019.05.22	NEW RELEASE

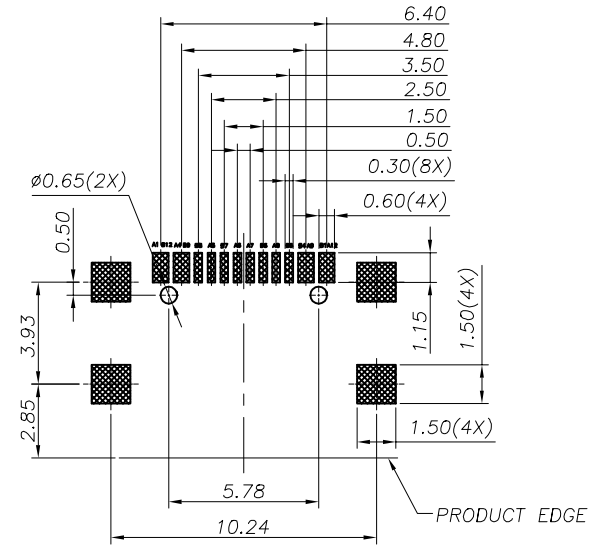
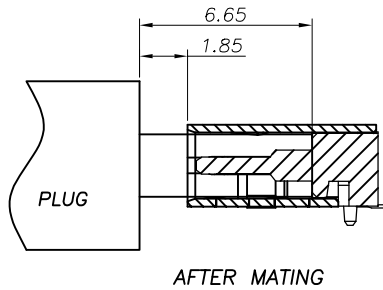

USB TYPE-C PIN ASSIGNMENTS

PIN NUMBER	SIGNAL NAME	PIN NUMBER	SIGNAL NAME
A1	GND	B12	GND
A4	VBUS	B9	VBUS
A5	CC1	B8	SBU2
A6	Dp1	B7	Dn2
A7	Dn1	B6	Dp2
A8	SBU1	B5	CC2
A9	VBUS	B4	VBUS
A12	GND	B1	GND

PART NO.: SEE THE PART NUMBER CODE		GOLDCONN TECHNOLOGIES COMPANY LIMITED		DRAWN BY SAM	DATE 2019.05.22
GENERAL TOLERANCES (UNLESS SPECIFIED)		TITLE USB CF 16PIN L=7.35 SMT TYPE		CHECKED BY JAY	DATE 2019.05.22
QUALITY SYMBOL	0	DWG.NO.	CF179-16-02	APPROVED BY JACKY	DATE 2019.05.22
x.xxxxx	± ---	DIMENSION STYLE	MM ONLY	THIRD ANGLE PROJECTION	
x.xxx	± 0.10	DESIGN UNITS	METRIC	SCALE	
x.xx	± 0.20	SHEET NO.	2 OF 2	1:1	
x.x	± 0.30	frame size: A4			
ANGULAR	± ---°				