

REV	ECN No.	DATE	REMARK
A	NEW	2020.11.25	新版发行

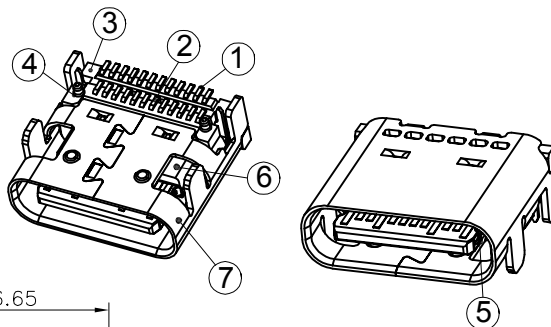

NOTE:

- MECHANICAL PERFORMANCE
 - 1-1.INSERTION FORCE: 0.5~2.0kgf.
 - 1-2.REMOVAL FORCE: 0.8kgf~2.0kgf.
 - 1-3.DURABILITY: 10000 CYCLES.
- ELECTRICAL PERFORMANCE
 - 2-1. CURRENT RATING:5.0A
VOLTAGE RATING:5.0V
 - 2-2. LCR: VBUS & GND PINS AND OTHER PINS: 40mΩ/PIN MAX.
SHIELD: 50mΩ/MAX.
LCR MAX. CHANGE OF ALL PINS: 10mΩ.
 - 2-3.INSULATION RESISTANCE: 100MΩ MIN
 - 2-4.DIELECTRIC WITHSTAND VOLTAGE,AC 100V FOR 1 MINUTE.
- ENVIRONMENTAL PERFORMANCE:
 - OPERATING TEMPERATURE: -25°C~+85°C.
- IR REFLOW:
 - THE PEAK TEMPERATURE ON THE BOARD SHALL BE MAINTAINED FOR 10 SECONDS AT 260°C.
- PART NUMBER CODE: (产品料号)
USF04-2 X X 2 XX-023 XX-02
(1) (2) (3) (4)

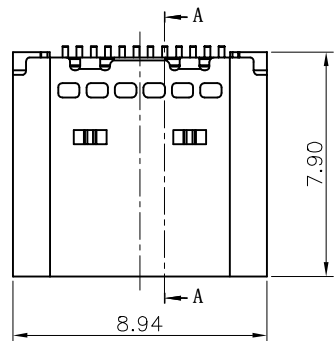
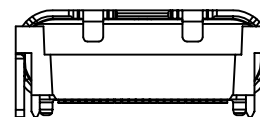
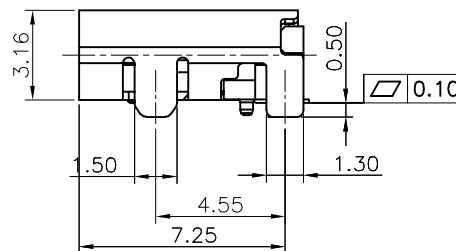
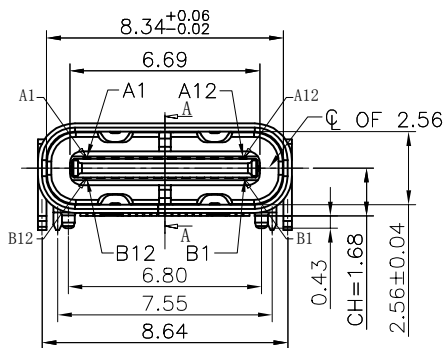
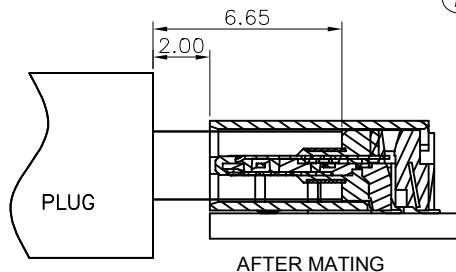

- HOUSING MATERIAL:
 - 2:LCP
 - 3:PA9T
- HOUSING COLOR:
 - 1:BLACK
- CONTACTS PLATED:
 - 12:接触镀金3u"焊接区域镀金1u"
 - 14:接触镀金15u"焊接区域镀金1u"
 - 15:接触镀金30u"焊接区域镀金1u"
 - 02:半金锡3u"
- PACKING OPTIONS
 - R:卷装(常用料)
 - VR:卷装+真空包装(专用客户指定包规)

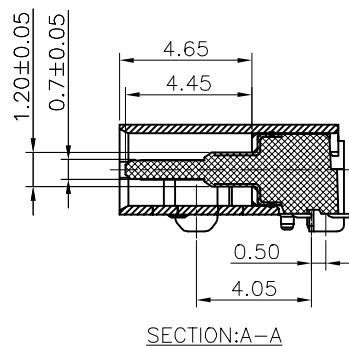
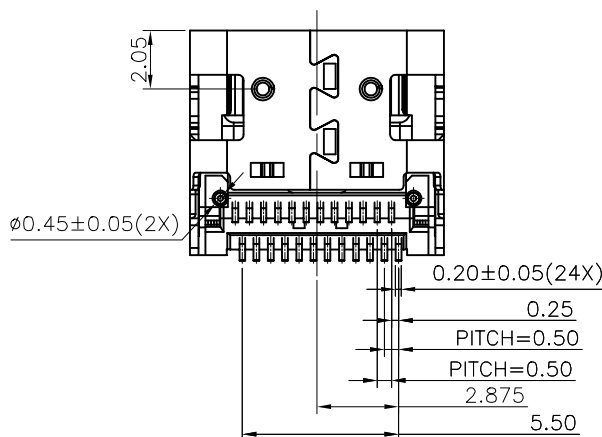

TYPE:

7	SHELL	1	SUS304 T=0.30	Ni 30u" MIN. UNDER PLATED OVER ALL.
6	EMI	1	SUS304 T=0.10	CLEAR ONLY
5	SHIELDING PLATE	1	SUS301 T=0.15	Ni 30u" MIN. UNDER PLATED OVER ALL. Sn 80u"MIN. PLATED OVER ALL
4	INSULATOR 2	1	LCP/PA9T UL94V-0	COLOR:BLACK
3	INSULATOR 1	1	LCP/PA9T UL94V-0	COLOR:BLACK
2	Down CONTACT	12	C18400 T=0.12	Ni 50u" MIN. UNDER PLATED OVER ALL
1	TOP CONTACT	12	C18400 T=0.12	Au PLATED ON CONTACT/Sn PLATED ON SOLDERING
No.	PART NAME	Q'TY	MATERIAL	FINISH

PART NO.: SEE THE PART NUMBER CODE		GOLDCONN TECHNOLOGIES COMPANY LIMITED		DRAWN BY SAM	DATE 2020.11.25	
QUALITY SYMBOL 0 ∇ 0	GENERAL TOLERANCES (UNLESS SPECIFIED)		TITLE USB C F 双排板上SMT有柱			
	x.xxxx	± ---	DWG.NO. ED-UC-009	SHEET NO. 1 OF 2	CHECKED BY JAY	DATE 2020.11.25
	x.xxx	± 0.10			APPROVED BY JACKY	DATE 2020.11.25
	x.xx	± 0.25			THIRD ANGLE PROJECTION	
x.x	± 0.30					
ANGULAR	± ---°	DIMENSION STYLE MM ONLY	DESIGN UNITS METRIC	SCALE 1:1	frame size: A4	

